

# Minutes

Bicentennial Equestrian Park  
Reference Group Meeting  
Camden BEP Main Pavilion

Wednesday 14<sup>th</sup> August 2024



## MEETING DETAILS

**Date:** 14/8/2024

**Location:** Camden BEP

**Scheduled Time:** 7:00pm

**Meeting opened:**

7:05 pm.

**Meeting closed:**

8:30pm

**Chairperson :**

Warren Death

**Minute taker:**

Kieran Berryman: Camden Council (ex officio)

**Acknowledgement of Country:**

Acknowledgement read by Chairperson

---

## ATTENDANCE

### Present:

- Warren Death, community member (chair)
- John Vallance, community member
- Jason Sharpe, community member
- Greg McDonald, Camden Harness Club
- Charlotte Hyles Camden Harness Club (alternate)
- Rebecca Golowenko, Cobbitty Pony Club (abs)
- Kieran Berryman, CCSO, Camden Council (ex officio)

### Apologies and Absences:

- Jeff Ferrif, community member
- Garry Clarke, Eventing Equestriad Australia
- Sandy Davies, Camden Show Society
- James Mathers, Sydney Polocrosse Club
- Norm Flegg, County of Cumberland Campdraft Club
- Elysha Sargent, community member
- John Kelly, community member
- Shane Rose, Eventing Equestriad Australia (alternate)
- Jo Tapp, Camden Show Society (alternate)
- Councillor Eva Campbell, Camden Council
- Hayley Neville, Mgr. Economic Development and Activation, Camden Council. (ex officio)

### Visitors & Guests:

- Phillipa Percy Camden Council

**Motion:** That the apologies be noted and leave of absence granted.

**Moved:** Jason Sharpe, **Seconded:** John Vallance

***Motion Carried***

---

## CONFIRMATION OF MINUTES FROM PREVIOUS MEETING

No Changes

**Motion:** That with the above changes the minutes are true and accurate reflection of the previous meeting.

**Moved:** Charlotte Hyles, **Seconded:** John Vallance

*Motion Carried*

---

## BUSINESS ARISING FROM PREVIOUS MEETING (not contained in action log)

- Nil
- 

## CHAIRPERSON REPORT – Jeff Ferrif (in absentia)

- As tabled (attached)

**Motion:** That the Chairpersons report be accepted.

**Moved:** Warren Death, **Seconded:** Rebecca Golowenko

*Motion Carried*

---

## AGENDA ITEMS

1. Nil
- 

## ACTION LOG/PROJECTS

**17-021 – Steel horse yards** : Numbering still to be completed. Some signage still to be installed.

**19-017 – Washbays** : Tender/RFQ open. Closes in August. Quad washbays will be 4xinline and front rails for all will be double.

**23-001, General Litter Bins at BEP.** Slabs placed. Stands awaiting to be installed.

**23-003 Annual Equestrian Muster** : To be included in Music Event.

**23-004 XC Jumps & Course Fees** : No Update. Kieran Berryman to write up and provide feedback.

**23-008 Annual Maintenance plan** –No Update TL Kieran Berryman will update the management plan.

**23-009 New Master Plan** : Consultant still to be engaged.

**24-001 Cobbitty Pony Club grant works** : CPC will contribute approx. \$10,000 to washbays. Rebecca & Elysha to confirm in writing.

**24-005 EEA International Event** : TL Kieran Berryman discussing options for sponsorship and promotion with Council economic development team.

**24-007 Community Music Event** : No Update. Hayley Neville and TL Kieran Berryman to provide Ref. Grp with updates as the event details become clearer.

**24-008 Closing arena surfaces after large events for repairs and rest** : TL Kieran Berryman to review and discuss with Parks team about reparations periodically and after larger events that would require arena closure.

**24-010 Rec Rider Day rate** : Rate already in schedule of fees. Precinct team looking at how Bookable system can be configured.

**24-011 Main – Polox bridge repairs.** : Works planned for Sept. TL Kieran Berryman will update when schedule confirmed.

---

## Councillor Update

- Nil.
- 

## USER GROUP UPDATES

### Camden Show Society

- AGM shortly.

### Eventing Equestriad Australia

- Nil

### Cobbitty Pony Club

- State Show Jumping next month.
- Some Camden Show dog show equipment still in clubhouse.
- Trees on approach to causeway need trimming

### Sydney Polocrosse Club

- Nil

### Cumberland Campdraft Club

- Bison Clinic being held late Sept.

### Camden Harness Club

- As tabled
  - Some shavings left in yards after club event
  - Incident with P-Plater driving dangerously within the grounds during event.
    - CCTV to capture rego details would be beneficial.
    - Look at options for locking arena areas
    - Add to annual risk assessment.
  - Members renewing their memberships.
  - Club has received a grant through Sallie Quinell MP for timing equipment and other items.
-

## **BEP Calendar and Events update : Precinct Team**

- New rec rider season commenced 1/7.
  - 90+ registered so far including 20-30 new members
  - Call for 2025 calendar will start 1/9
- 

## **GENERAL BUSINESS**

- FYI Next meeting will be an end of Council term thankyou BBQ with food & bevies. Director Cas Mehmed and others will attend.
- 

**Meeting Closed 8:30pm**

DRAFT

## Camden BEP Chairpersons Report 14<sup>th</sup> August 2024

Hello All,

Apologies for not being in attendance tonight. I'm on a bit of a grand tour at present having just been out to the White Cliffs Gymkhana and Rodeo and now in Surat Queensland at the 100 years of Cobb & Co Festival celebrating Draft Teams, Camels and Horses. I retract everything I've ever said about this great State. Go Queensland!

Thanks to everyone for their valuable contribution and input at last months meeting especially relating to the proposed large music event proposed to be held at the Park. I appreciate that everyone spoke openly and passionately in the interests of protecting the Park that we have all worked so hard to develop and grow. I appreciate Council staff Hayley and Kieran for fronting up and being party to a robust discussion. I think we as a group gained some important concessions from Council around how the Park would be used, what areas we consider suitable for this type and scale of event and removing the risk of vehicle damage entirely from the Park. As I said last month time will tell if Council listens to us as it's own equestrian advisory body.

Annoyingly there's been some minor vandalism around the place. We and all our park users need to be vigilant about locking gates and bathrooms so these cretins have fewer opportunities to do damage.

Kieran and Myself met with Mick Kearney at K-Ranch and inspected a lot of the infrastructure he will soon have up for sale when K-Ranch shuts it's doors. The Park and Council may be able to secure some quality equestrian kit that would further lift the standard of the Park for very reasonable prices.

Congrats to Olympian Shane Rose representing the BEP (and also Australia) on the world stage in Paris. A great effort to even get there after a tumultuous year. Well done Shane, Virgil and your support team.

Thanks

Jeff Ferrif  
BEP Chairperson  
0410 585 785



Current Actions

Action # & Start Date	Initiator & Action/Project Description	Who Actioning	Action/Project Log & Status
17-021 2017	CCSO/355 Committee Install steel horse yards	CCSO	<p>14/7/22 – Task transferred from 355 Committee</p> <p>10/8/22 – Small project to be run to complete works. CCSO to coordinate.</p> <p>10/5/23 - <i>Reactivated</i>. Request for quotations for earthworks being issued this month.</p> <p>14/6/23 - Request for quotations issued for yard pads. Update next month.</p> <p>9/8/23 - TRN selected. Works starting in next week.</p> <p>8/11/23 - Shale Pads completed. Daytime working bee good. Afternoon working bee failed. More will be planned over next few months.</p> <p>14/2/24 - Working bees held and yards installed. Still works for Southern end prior to Campdraft event and Pony Club to be completed.</p> <p>13/3/24 – 10/4/24 Still Pony Club to do and some more for pads near main arena.</p> <p>8/5/24 – 12/6/24 All yards installed (238). Numbering still to be completed. Some signage still to be installed.</p> <p>10/7/24 – 14/8/24 Numbering still to be completed. Some signage still to be installed.</p>
19-017 2019	CCSO/355 Committee BEP Wash bays	CCSO	<p>14/7/22 – Task transferred from 355 Committee</p> <p>10/8/22 – Small project to be run to complete works. CCSO to coordinate.</p> <p>10/5/23 - <i>Reactivated</i>. Precinct team will commence works in new financial year.</p> <p>14/6/23 – 9/8/23 Precinct team will commence works in new financial year.</p> <p>8/11/23 - On Hold pending budget confirmation.</p> <p>8/5/24 - Quotes being sought for immediate works.</p> <p>12/6/24 - Quotes being sought to construct at Southern &amp; Pony Club. Timber posts &amp; rails to be replaced with cattle rail at Main.</p> <p>10/7/24 – 14/8/24 Tender/RFQ open. Closes in August. Quad washbays will be 4 x inline and front rails for all will be double.</p>





Action # & Start Date	Initiator & Action/Project Description	Who Actioning	Action/Project Log & Status
20-004 2020	CCSO/355 Committee Implement irrigation water plan	CCSO	14/7/22 – Task transferred from 355 Committee 10/8/22 – Project to be run to complete works by Council Major Projects. CCSO to coordinate. 10/5/23 – 14/6/23 - <i>Reactivated</i> : TL to reactivate and raise with Council for works to commence. 9/8/23 - Will be included in overall masterplan consultation. On Hold
20-015 2020	CCSO/355 Committee Install new EEA bridge	CCSO	14/7/22 – Task transferred from 355 Committee 10/8/22 – Project to be run to complete works by Council Major Projects. CCSO to coordinate. 9/11/22 – Reactivated for action. 14/12/22 – No Action.
21-005 2021	CCSO/355 Committee Extend formal roadway network.	CCSO	14/7/22 – Task transferred from 355 Committee 10/8/22 – Project to be run to complete works by Council Major Projects. CCSO to coordinate.
22-003 10/8/2022	Warren Death Emergency disease outbreak planning at BEP	CCSO & Whole Ref. Grp.	10/8/22 - BEP Ref Grp. members to consider infrastructure requirements or models at other venues for defined isolation areas. 14/9/22 - Propose dedicated room/stable/treatment box at each BEP precinct. 4 in total. CCSO to seek advice from Dr. Tony Mogg for requirements for such rooms. Also propose a float with screens to deal with horse fatality onsite. 12/10/22 - CCSO to seek advice from Dr. Tony Mogg for requirements for such rooms. 9/11/22 - 6x5m shed with stainless steel fittings, HWS, sink, , suitable large door and Personal Access Door. CCSO to distribute base requirements for review. 14/12/22 - Add treatment room to masterplan. ON HOLD



Action # & Start Date	Initiator & Action/Project Description	Who Actioning	Action/Project Log & Status
22-005 14/9/2022	CCSO Proposal from Camden Rotary to construct a memorial monument adjacent to BEP	Kieran Berryman	14/9/22 - CCSO to distribute the handout material to all Reference Group and for members to take to their respective for consideration at next BEP meeting. 12/10/22 - CCSO to submit Ref. Grp. recommendation for the Rotary Emergency Services memorial to Council for consideration. 9/11/22 – 14/12/22 Recommendation submitted to Council officers. No update 8/2/23 – 12/4/23 Council is considering options for memorial. 10/5/23 – No Update ON HOLD
23-001 8/2/2023	Lauren Cranfield General litter bins at BEP	Kieran Berryman TL	8/2/22 - KB TL to check with waste team about options for adding bins within the BEP for general litter collection. 8/3/23 – 12/4/23 Precinct team working with waste team to get public bins located and installed. WIP 10/5/23 – 14/6/23 Precinct team working with Waste Team to get public bins located and installed 9/8/23 – 8/11/23 Slabs and stands on order 14/2/24 – 12/6/24 Slabs and stands awaiting to be installed. 10/7/24 – 14/8/24 Slabs placed. Stands awaiting to be installed.
23-003 12/4/2023	Kieran Berryman TL BEP Annual Equestrian Muster event	Kieran Berryman TL	12/4/23 – 9/8/23 TL Kieran Berryman to compile more details of potential annual muster event to be held at the BEP. 8/11/23 – 8/5/24 - On Hold - TL Kieran Berryman discussing concept with Council events team. 10/7/24 - 14/8/24 To be included in Music Event .



Action # & Start Date	Initiator & Action/Project Description	Who Actioning	Action/Project Log & Status
23-004 10/5/2023	Garry Clarke EEA XC jumps and XC course fees	Kieran Berryman TL	<p>10/5/23 – 14/6/23 TL Kieran Berryman to recirculate previous modelling completed for effect of changing from current fees structure to proposed fee structure.</p> <p>9/8/23 - Fee modelling distributed. Not enough attendees for discussion.</p> <p>8/11/23 – 8/5/24 Kieran Berryman to meet with EEA re options for charging for use of grounds and fee.</p> <p>12/6/24 - TL Kieran Berryman &amp; Garry Clarke met to discuss. Kieran Berryman to write up and provide feedback.</p> <p>10/7/24 - 14/8/24 No Update. Kieran Berryman to write up and provide feedback.</p>
23-008 8/11/23	Warren Death Annual Park Management Plan/Schedule	Kieran Berryman TL	<p>8/11/23 : TL Kieran Berryman to arrange meeting of interested people.</p> <p>14/2/24 - Meeting held, Kieran Berryman to compile and distribute for review.</p> <p>13/3/24 - Plan being assembled. Draft of discipline specific preparations developed. Kieran Berryman to distribute for user group feedback. To include restorative works post event.</p> <p>10/4/24 - Draft of discipline specific preparations developed and distributed to members for user group feedback. To include restorative works post event.</p> <p>8/5/24 - Grounds sub committee to meet to review &amp; discuss.</p> <p>12/6/24 - Feedback received from user groups. TL Kieran Berryman will update the management plan.</p> <p>10/7/24 - 14/8/24 No Update TL Kieran Berryman will update the management plan.</p>
23-009 8/11/23	Kieran Berryman Renew Masterplan	Kieran Berryman TL	<p>14/2/24 - Consultation session held with BEP RG. Community Survey to be distributed shortly. Kieran Berryman to send to all clubs and rec riders.</p> <p>13/3/24 - Survey link sent to all clubs, user groups and Rec Roders. 150 submissions so far. Closes April 3rd.</p> <p>10/4/24 - Survey closed. 200+ responses received. Data will be compiled and consultants engaged to commence interpretation and plannings.</p> <p>8/5/24 - Community survey results being analysed. Data will be compiled and consultants engaged to commence interpretation and planning.</p> <p>12/6/24 – 14/8/24 Consultant still to be engaged.</p>



Action # & Start Date	Initiator & Action/Project Description	Who Actioning	Action/Project Log & Status
24-001 14/2/24	Elysha Sargent Cobbitty Pony Club grant works	Elysha Sargent & Kieran Berryman TL	14/2/24 - Elysha Sargent to compose a list of proposed projects and Kieran Berryman to obtain advice whether Council would run projects and be funded through Pony Club.  13/3/24 – 10/7/24 No update  14/8/24 CPC will contribute approx. \$10,000 to washbays. Rebecca & Elysha to confirm in writing.
24-005 13/3/24	Garry Clarke EEA International event	Kieran Berryman	13/3/24 - TL Kieran Berryman to speak to Councils Events Team about assistance, promotion and sponsorship.  10/4/24 – 14/8/24 TL Kieran Berryman discussing options for sponsorship and promotion with Council economic development team.
24-007 12/6/24	Ref. Grp. Community music event	Kieran Berryman	12/6/24 - TL Kieran Berryman to provide feedback back to Council about Ref Grp opposition to the event being held at BEP  10/7/24 – 14/8/24 Hayley Neville and TL Kieran Berryman to take feedback back to Council and to continue to provide Ref. Grp with updates as the event details become clearer.
24-008 12/6/24	Warren Death Periodic closure of Arenas	Ref. Grp.	12/6/24 - Ref Grp to further consider periodic closure of arenas after events or as required to protect/repair surfaces.  10/7/24 – 14/8/24 TL Kieran Berryman to review and discuss with Parks team about reparations periodically and after larger events that would require arena closure
24-010 10/7/24	Jo Tapp Rec Rider Day rate	TL Kieran Berryman	10/7/24 – 14/8/24 Rate already in schedule of fees. Precinct team looking at how Bookable system can be configured.
24-011 10/7/24	TL Kieran Berryman Main – Polox bridge repairs	TL Kieran Berryman	10/7/24 – 14/8/24 Works planned for Sept. TL Kieran Berryman will update when schedule confirmed.



**Closed Actions :** Closed actions will be removed (hidden) from the current log active at the subsequent meeting

Action # & Start Date	Initiator & Action/Project Description	Who Actioning	Action/Project Log & Status

## CAMDEN HARNESS CLUB - August 2024 Report

It's been a very wet month causing cancellation of events and Clinics for us.

Our long awaited "Ashes" competition had to be postponed to the October long-weekend.

Australia really wants to show the rest of the world how much fun we all have 'Down Under' with our Driving activities and hope to 'BRING HOME THE ASHES' - Again! We will again be able to watch everything via the Live Streaming by Horse & Country TV.

The U.K. is desperate to take back this honour in 2024, as it was a real shock to them, that Australia in 2023 could even be thought as fierce competition - but anyway the Aussies did it, so now we have to keep up the 'Anti' and shock them for a second time!

CHC Orienteering meeting went well. We put lollies in buckets and had Dog walkers telling us where the buckets were! Party goers were setting up in the polocrosse pavilion and flagged us down so children could see us and respectfully asked to approach to take photos. There were huge compliments for the park and strong interest in joining the recreation drivers group.

It was Great to see our Shane Rose, compete once again at the Olympics, even though the eventing team had bad luck with the withdrawal of Kevin McNab's horse. However, Queenslander Chris Burton did Australia proud winning the Silver medal in the individual 3 day event on Shadow Man (Fidgy)

Choccie immediately made us aware that the new main arena wash bays need a lower front rail for our smaller equines. Kieran has addressed this matter and park engineers are about to rectify this oversight!

This year's green park recreation driver tags have arrived and are displayed on our vehicles.

CHC postponed Dressage meeting, finally went ahead last Saturday on the pony club grounds. We were blessed with a magnificent sunny day and as is now normal, there was great camaraderie and endless compliments on how wonderful the park is.

### Washbay Layout and Specification

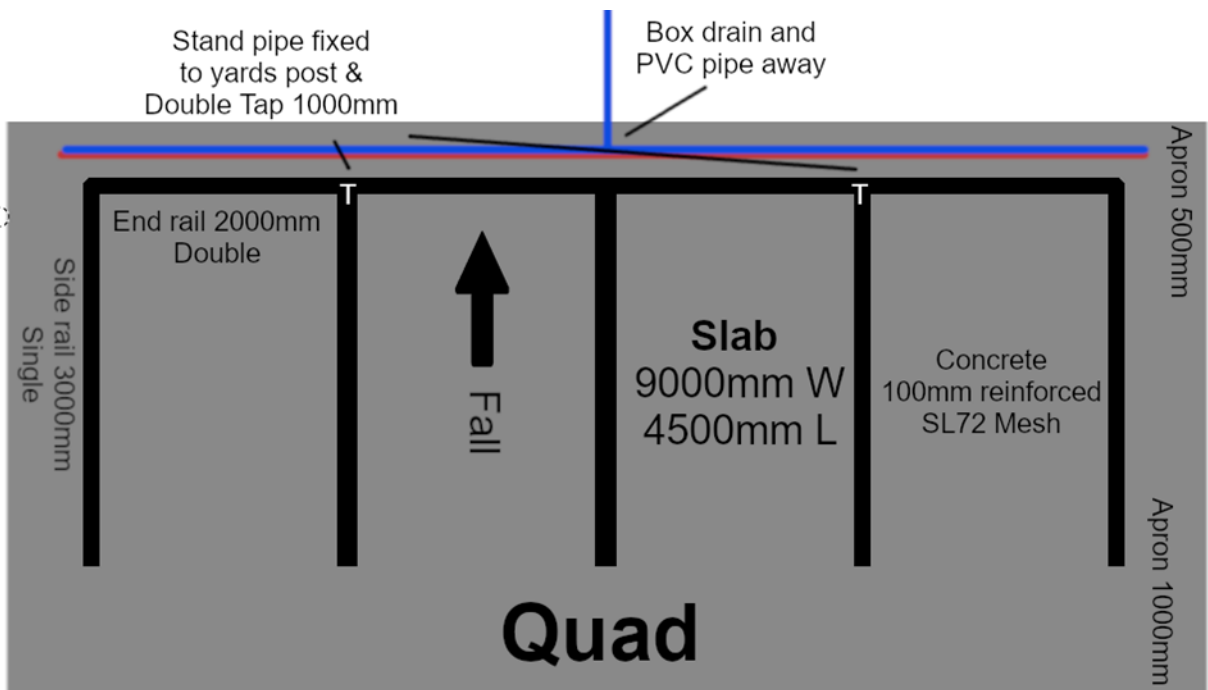
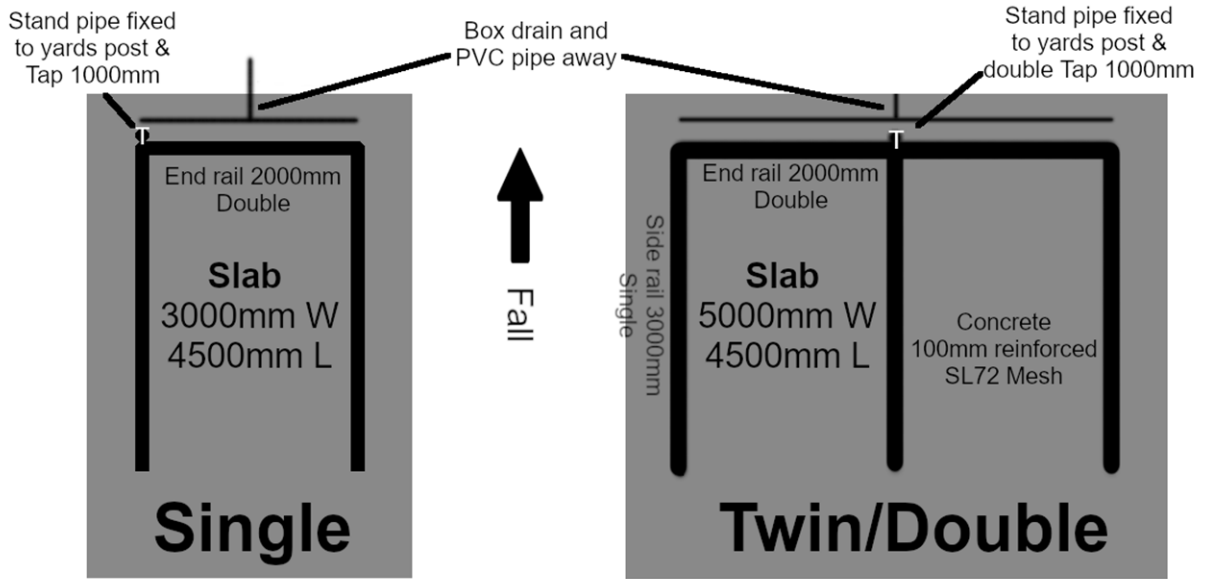

### Single Rail Washbay post & rail spec.

Fence - **1300mm** finish height

#### Posts

- RHS gal 65mm x 65mm
- 2.5mm wall thickness
- 2400mm long
- Slot cut to fit oval cattle rail 20mm
- Driven to a depth approx. 1100mm prior to slab pour
- Gal cap to be fitted

#### Rail

- Gal cattle rail
- 115mm x 42mm
- 2mm wall thickness
- 20mm bead welded in place

Diagram 1

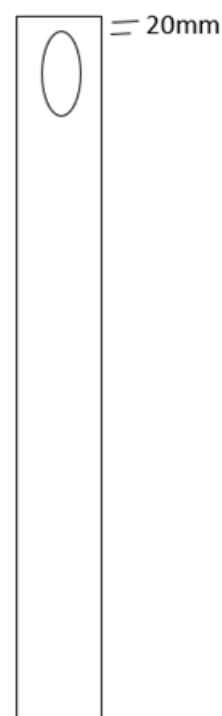

### Double Rail Washbay post & rail spec (front rails).

Fence - **1300mm** finish height

#### Posts

- RHS gal 65mm x 65mm
- 2.5mm wall thickness
- 2400mm long
- Slot cut to fit oval cattle rail 20mm and 585mm from top of post
- Driven to a depth approx. 1100mm prior to slab pour
- Gal cap to be fitted

#### Rail

- Gal cattle rail
- 115mm x 42mm
- 2mm wall thickness
- 20mm bead welded in place

Diagram 2

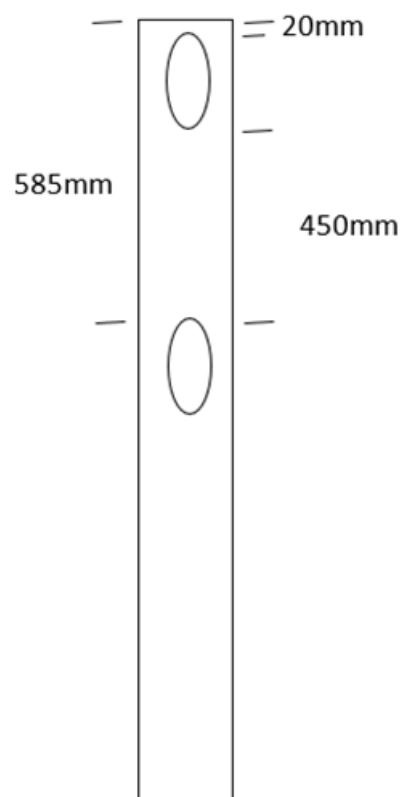



Sample Images





### Slab Section

